

Order no:	-1	COVER (A1)	INNER COVER (B1/B2)	INNER COVER (C1/C2)	SHEETS (D1/D2)
Article:	HAPU A6	Technique:	Logo colours:	Logo colours:	Logo colours:
Quantity:	-	Logo size:	Size of logo:	Size of logo:	Size of logo:
Elastic band:	-	PU cover color:			Type of paper: lined / squared
Ribbon:	-				
Sizes:	Standard				

HAPU A6
scale 1:1

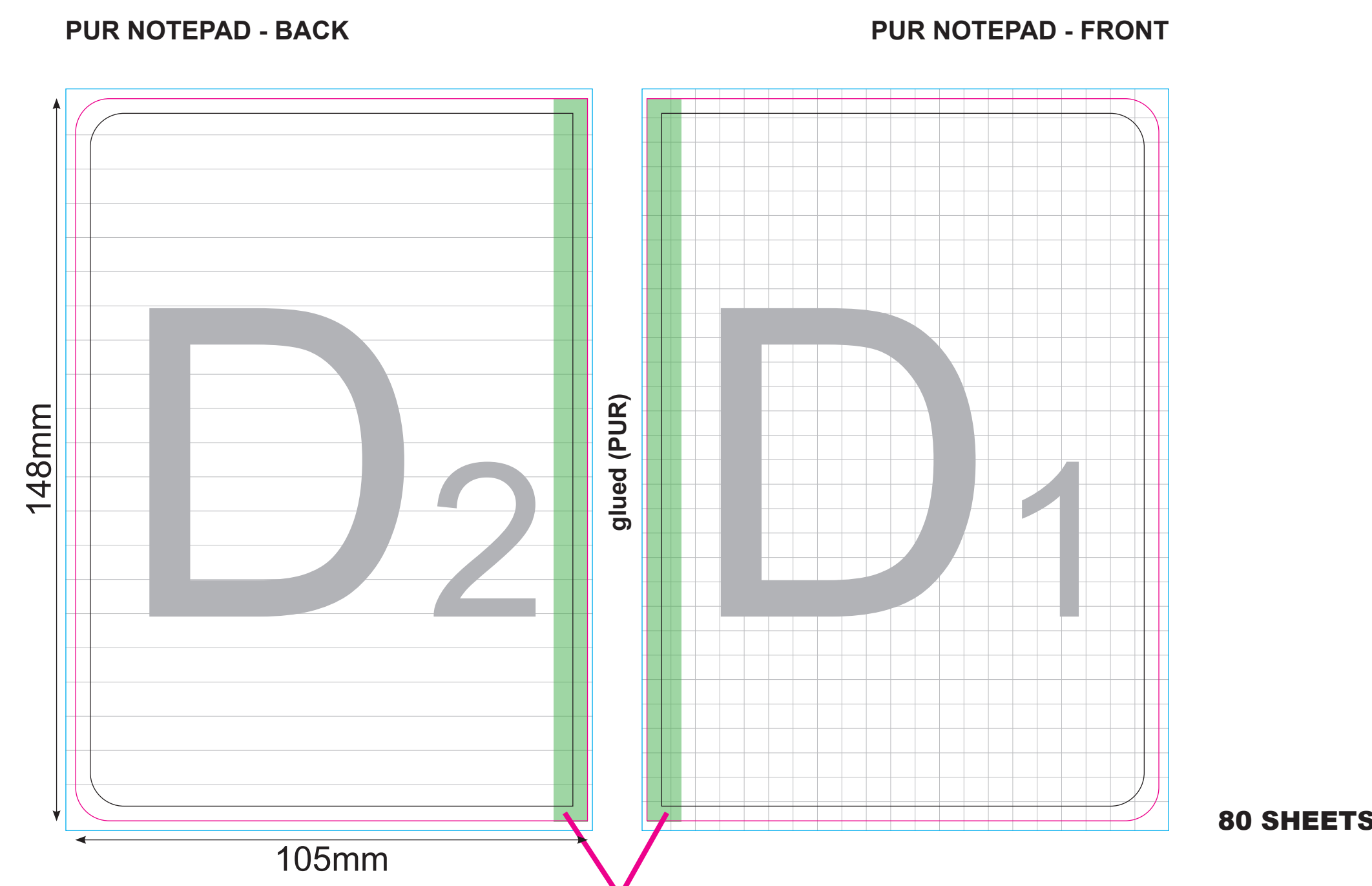
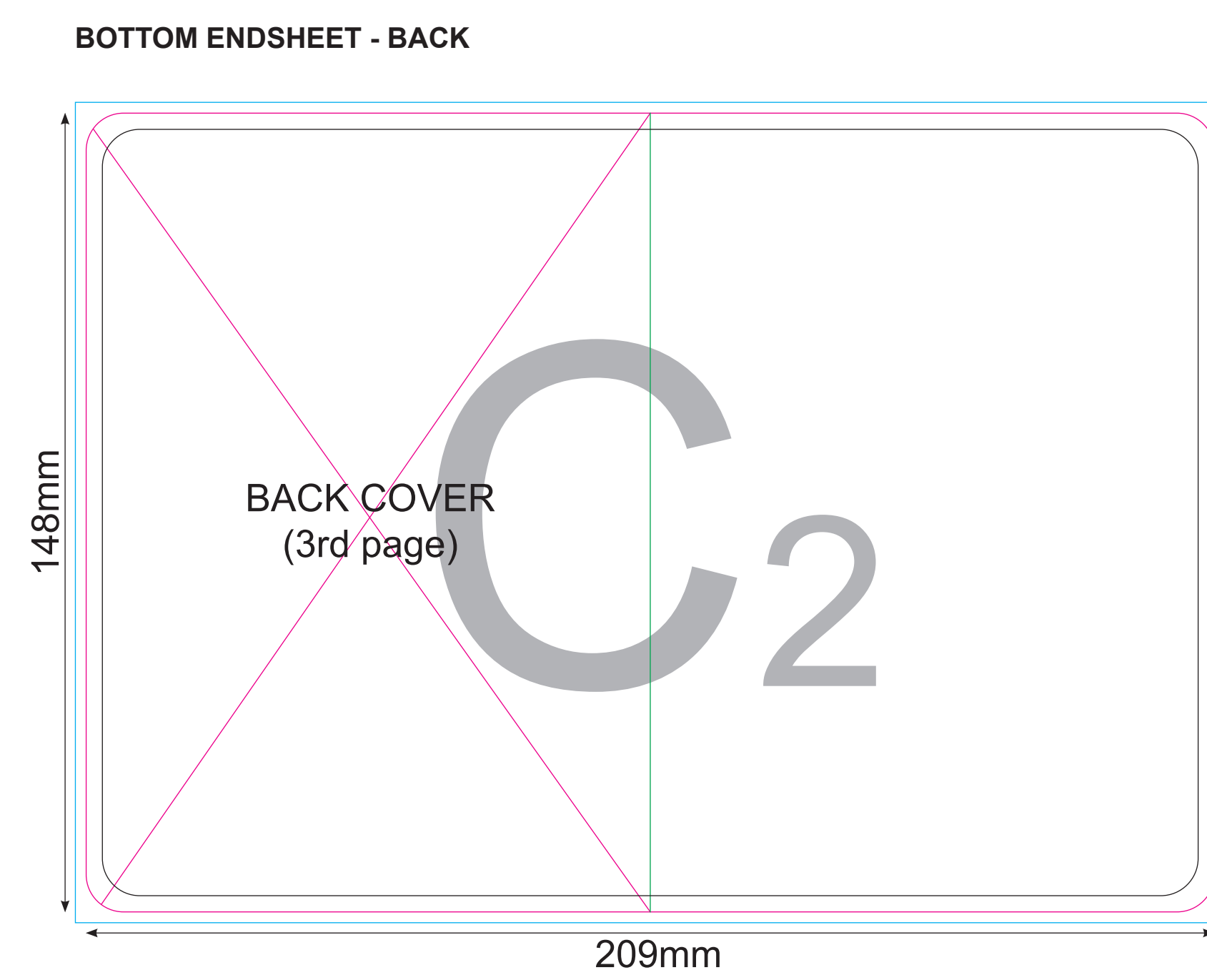
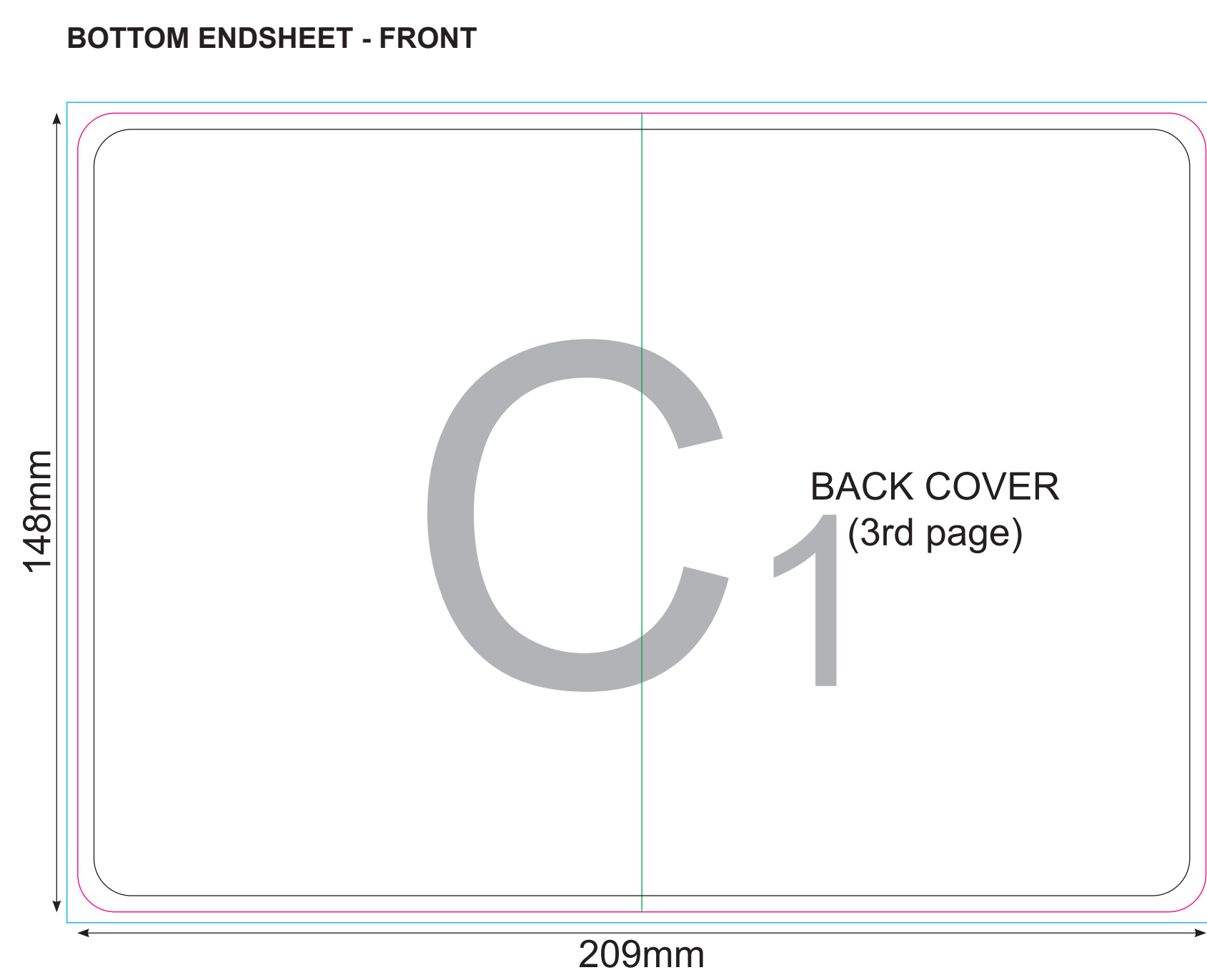
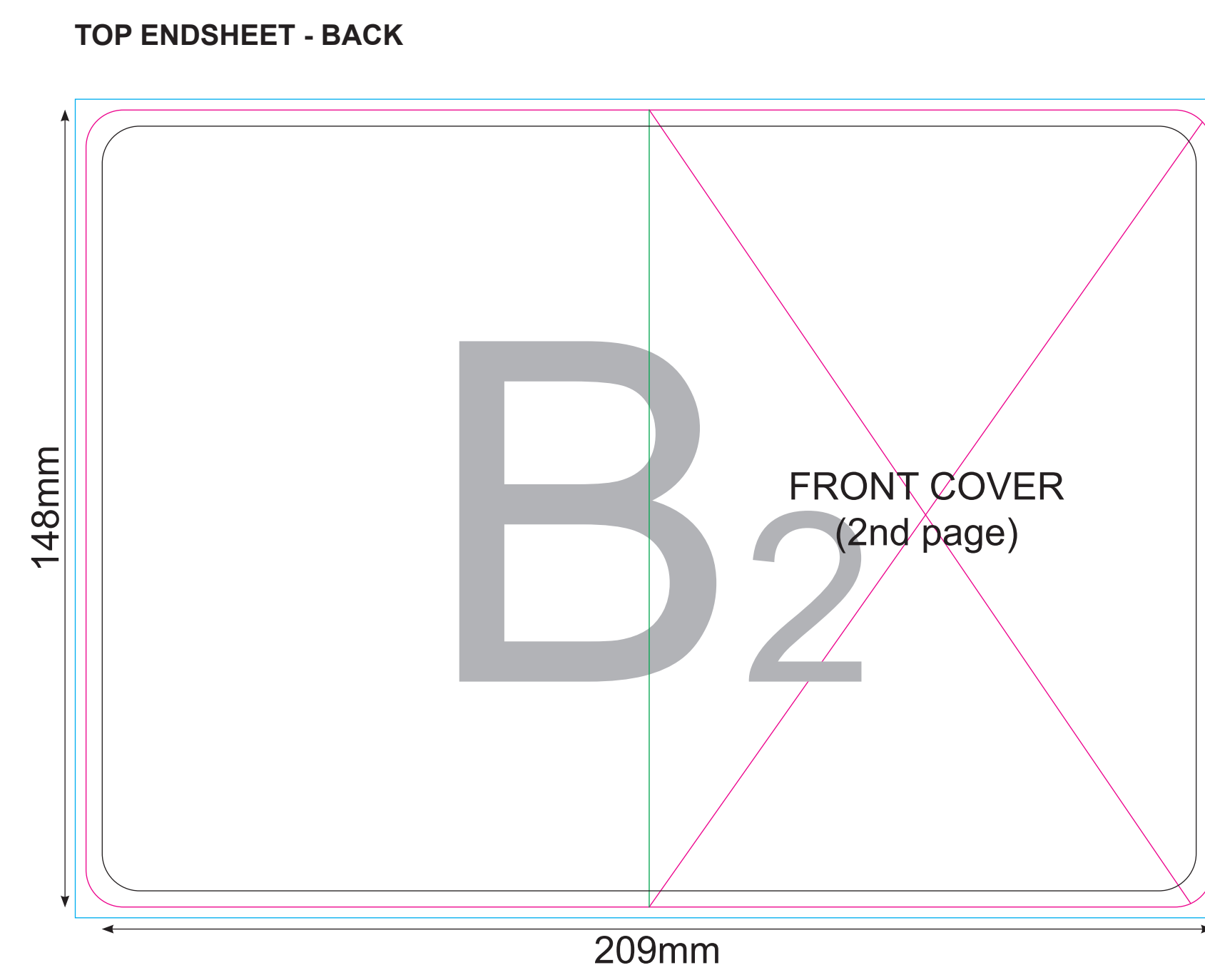
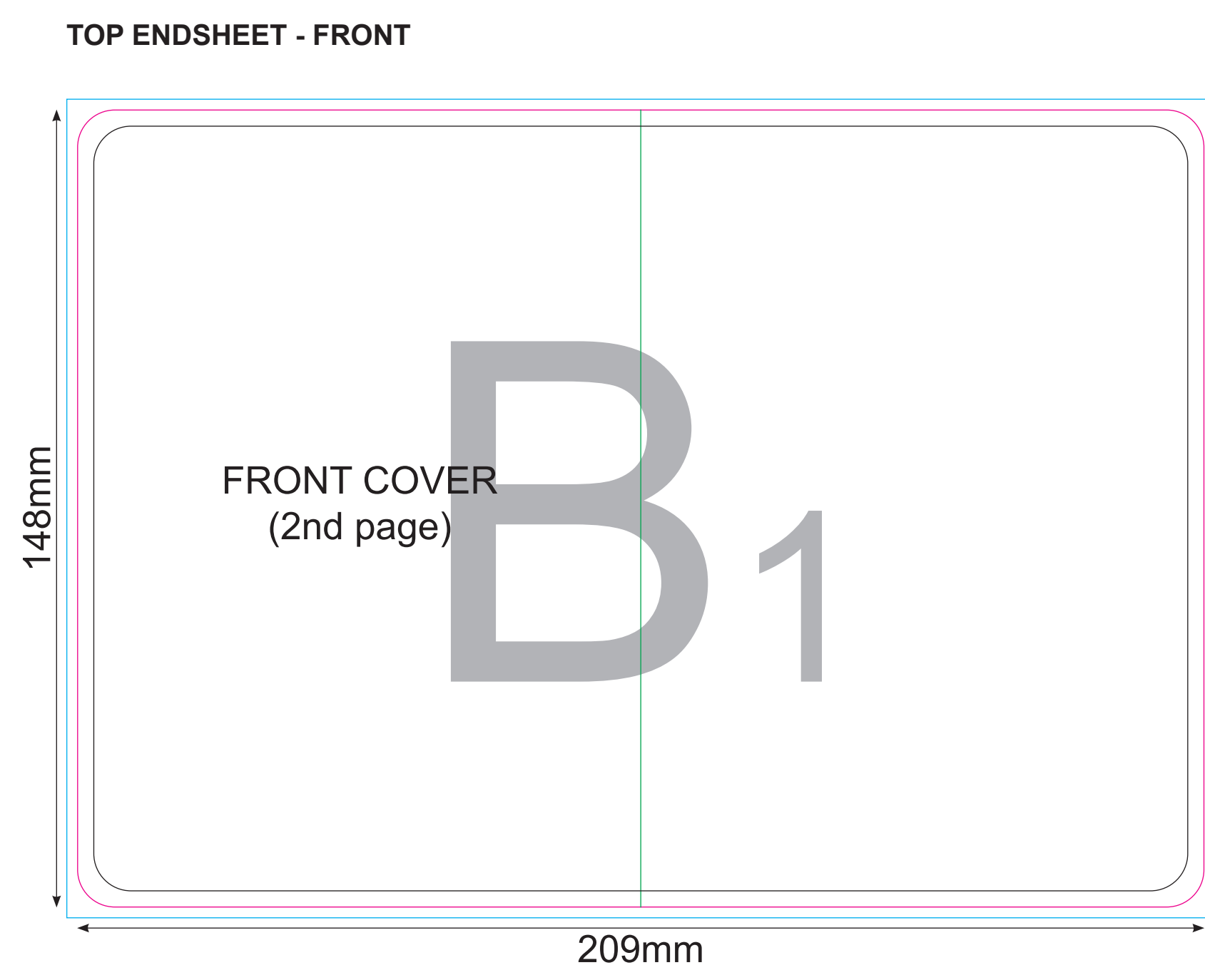
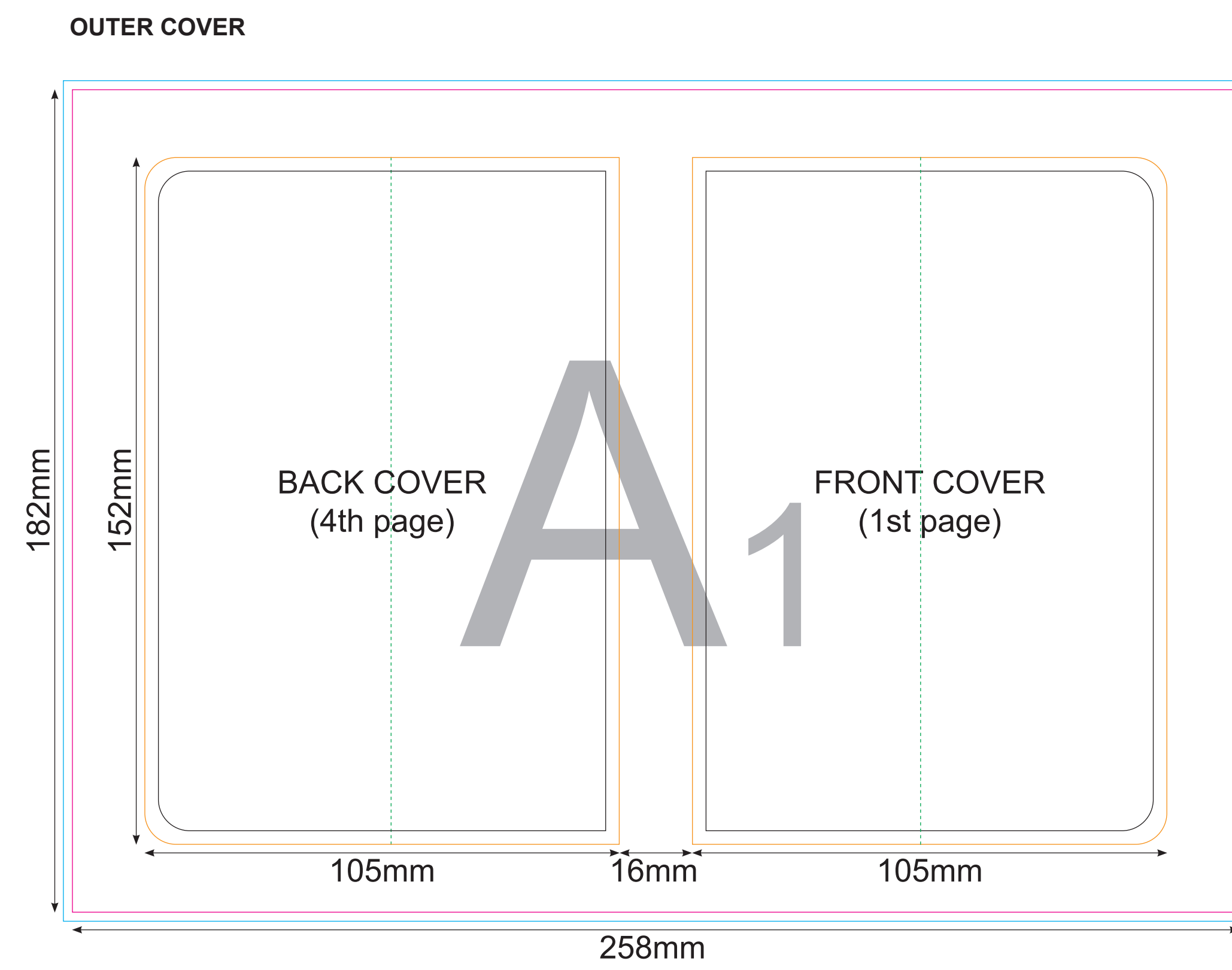
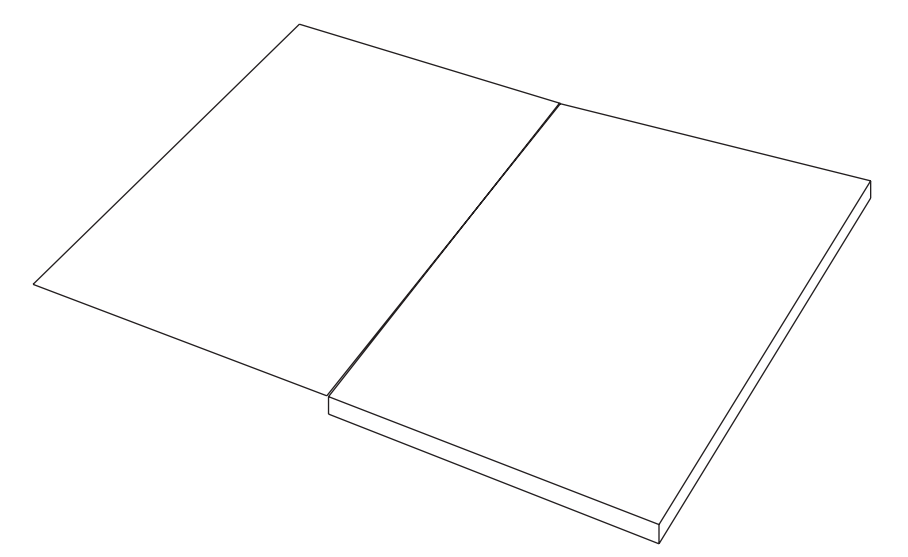

Important:
First page is glued to the inner cover approx. 7mm from the binding margin.
Last page is glued to the inner cover approx. 7mm from the binding margin.

- Key:
- Finished component size
 - Bleed area. In case of bleed imprint, please extend it until blue line
 - Safe print area. Keep all important text and graphics within this area
 - Solid Board
 - Axis of the Crease

PRODUCTION STARTS ONCE APPROVED

CLIENT APPROVAL

Please carefully check all details mentioned on this Artwork Approval Form.
Any changes made after approval will result in production delays and additional costs.
In order to achieve the delivery time, we need confirmation within 24 hours. Otherwise, the delivery time will be affected.

AUTHORISED SIGNATURE

COMPANY STAMP

A 1

B 1

B₂

C₁

~~CC₂~~

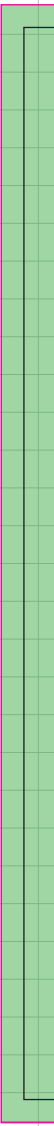

D

1

D 2